

OPERATOR'S SAFETY AND SERVICE MANUAL



482/483

This manual covers the following serial numbers
and higher for each model listed:

R482/R483.....4820001



SMART RAMMERS

MBW, Inc.
250 Hartford Rd • PO Box 440
Slinger, WI 53086-0440
Phone: (262) 644-5234
Fax: (262) 644-5169
Email: mbw@mbw.com
Website: www.mbw.com

MBW (UK) Ltd.
Units 2&3 Cochrane Street
Bolton BL3 6BN
England, UK
Phone: 44 (0) 01204 387784
Fax: 44 (0) 01204 387797
E-mail: mbwuk@btinternet.com

MBW FRANCE S.A.R.L.
Z.A. d'Outreville
11 Rue Jean Baptiste Néron,
60540 BORNEL
France
Email: mbwfrance@free.fr
Phone: +33 (0) 3 44 07 15 96
Fax: +33 (0) 3 44 07 41 28

L19905 04.11.A
©MBW, Inc. 2004
Printed in the USA

TABLE OF CONTENTS

Safety Information	1	Handle Removal	7
Introduction	1	Engine Removal	7
Safety Precautions	1	Centrifugal Clutch	8
Safety Decals	1	Gearbox Removal	8
Specifications	3	Crank Gear Removal	8
Operation	4	Pinion Removal	8
Introduction	4	Breather Assembly	8
Before Starting & Operating	4	Slide Bearing Removal	8
Starting Engine	4	Lower Unit	9
Operating	4	Bellows and Shoe	9
Stopping Engine	4	Springbox	9
Lifting and Transporting	4	Assembly Instructions	9
Maintenance	5	Gearbox Assembly	9
Maintenance Schedule	5	Lower Unit Assembly	10
Fluid Levels	5	Gearbox & Lower Unit Assembly	10
Engine Maintenance	5	Parts Replacement Cycles and Tolerances	11
Engine Speed	5	Replacement Parts	13
Checking Percussion System Oil	5	Gearbox Assembly	14
Changing Percussion System Oil	6	Lower Unit Assembly	16
Service	7	Gearbox and Lower Unit Assembly	18
Torque Chart	7	Handle Assembly	20
Service Tools	7	Engine Assembly	22
		Warranty	24



WARNING



CALIFORNIA PROPOSITION 65 WARNING

Engine exhaust and some of its constituents are known in the state of California to cause cancer, birth defects, and other reproductive harm.

SAFETY INFORMATION

Introduction



This Safety Alert Symbol is used to call attention to items or operations which may be dangerous to those operating or working with this equipment. The symbol can be found throughout this manual and on the unit. Please read these warnings and cautions, along with all decals, carefully before attempting to operate the unit. Make sure every individual who operates or works with this equipment is familiar with all safety precautions.

WARNING

GENERAL WARNING. Indicates information important to the proper operation of the equipment. Failure to observe may result in damage to the equipment and/or severe bodily injury or death.

CAUTION

GENERAL CAUTION. Indicates information important to the proper operation of the equipment. Failure to observe may result in damage to the equipment.

Safety Precautions



LETHAL EXHAUST GAS: An internal combustion engine discharges carbon monoxide, a poisonous, odorless, invisible gas. Death or serious illness may result if inhaled. Operate only in an area with proper ventilation. **NEVER OPERATE IN A CONFINED AREA!**



DANGEROUS FUELS: Use extreme caution when storing, handling and using fuels, as they are highly volatile and explosive in vapor state. Do not add fuel while engine is running. Stop and cool the engine before adding fuel. **DO NOT SMOKE!**



SAFETY GUARDS: It is the owner's responsibility to ensure that all guards and shields are in place and in working order.



IGNITION SYSTEMS: Breakerless, magneto, and battery ignition systems can cause severe electrical shocks. Avoid contacting these units or their wiring.



SAFE DRESS: Do not wear loose clothing, rings, wristwatches, etc. near machinery.



NOISE PROTECTION: Wear OSHA specified hearing protection devices.



EYE PROTECTION: Wear OSHA specified eye shields, safety glasses, and sweat bands.



FOOT PROTECTION: Wear OSHA specified steel-tipped safety shoes.



HEAD PROTECTION: Wear OSHA specified safety helmets.



DUST PROTECTION: Wear OSHA specified dust mask or respirator.

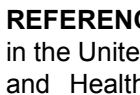

OPERATOR: Keep children and bystanders off and away from the equipment.

REFERENCES: For details on safety rules and regulations in the United States, contact your local Occupational Safety and Health Administration (OSHA) office. Equipment operated in other countries must be operated and serviced in accordance and compliance with any and all safety requirements of that country. The publication of these safety precautions is done for your information. MBW does not by the publication of these precautions, imply or in any way represent that these are the sum of all dangers present near MBW equipment. If you are operating MBW equipment, it is your responsibility to insure that such operation is in full accordance with all applicable safety requirements and codes. All requirements of the United States Federal Occupational Safety and Health Administration Act must be met when operated in areas that are under the jurisdiction of that United States Department.

Safety Decals

Carefully read and follow all safety decals. Keep them in good condition. If decals become damaged, replace as required. If repainting the unit, replace all decals. Decals are available from authorized MBW distributors. Order the decal set listed on the following page(s).

UNLEADED GASOLINE
14781
14781



THROTTLE
RUN
↑
↓
IDLE
14770

14770

CAUTION
Machine is top heavy and could fall if not lifted from this bar.
R422 = 138 lb (63 kg)
R442 = 150 lb (68 kg)
R482/483 = 177 lb (80 kg)

20258

AIR CLEANER INSTRUCTIONS
CLEAN ELEMENT DAILY. MORE OFTEN UNDER DUSTY CONDITIONS.
DIP ELEMENT LIGHTLY ON FLAT SURFACE. IF DUST DOES NOT DROP OFF EASILY OR IF ELEMENT IS BENT OR CRUSHED...
REPLACE IT.
WARNING: DO NOT OPERATE ENGINE WITHOUT AIR CLEANER ELEMENT - INTERNAL DAMAGE WILL RESULT!

06079

PATENT PENDING
01504



01064

CAUTION
Read the Operating Instructions before operating this piece of equipment.
Keep unauthorized and untrained people away from this equipment.
ROTATING & MOVING PARTS! Make sure all guards and safety devices are in place.
Wear approved hearing protection, foot protection, eye protection and head protection.
SHUT OFF the motor before servicing or cleaning.
DO NOT RUN in an enclosed area. The engine produces carbon monoxide, a **POISONOUS GAS**.
Failure to comply could result in serious bodily injury.

13843

REMINDER
CHECK ENGINE OIL DAILY.
ENGINE MUST BE LEVEL.

15137

DANGER PELIGRO
Compressed spring could cause severe injury. See manual for disassembly instructions.
La resorte comprimida podría causar la herida severa. Consulte el libro para ver el desmontaje correcto.

01326

OPERATING INSTRUCTIONS
1. Check fuel level.
2. Open fuel valve.
3. Set throttle at idle position.
4. Choke engine. A warm engine may not need to be choked.
5. Pull starter rope.
6. After starting, open choke gradually and let engine warm up at idle.
7. To start compacting: open throttle fully.
8. To stop: return throttle to idle and allow engine to run for a few minutes before turning off.
9. Turn engine switch to off and close fuel valve.

14773

OPTIMAL OPERATING SPEED
420-421/422... 3500 RPM
440/442... 3500 RPM
480-481... 3200 RPM
482-483... 3200 RPM

15287

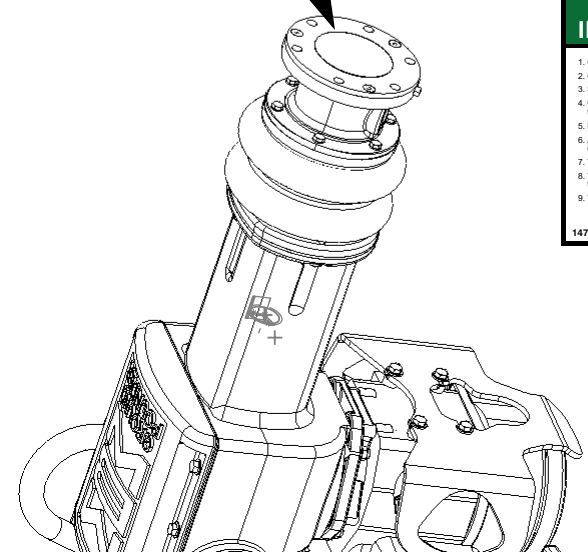

Safety Decals (Decal Set #)

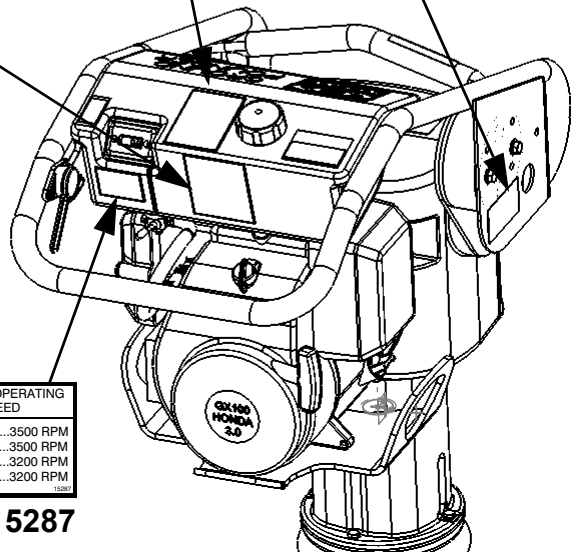

OPERATION

Introduction

MBW equipment is intended for use in very severe applications. They are powered by four cycle engines and are available in different sizes and a selection of engines.

This parts manual contains only standard parts. Variations of these parts as well as other special parts are not included. Contact your local MBW distributor for assistance in identifying parts not included in this manual.

Before Starting & Operating

- REMEMBER! It is the owner's responsibility to communicate information on the safe use and proper operation of this unit to the operators.
- Review ALL of the Safety Precautions listed on page 1 of this manual.
- Familiarize yourself with the operation of the machine and confirm that all controls function properly.
- Know how to STOP the machine in case of an emergency.
- Make sure hands, feet, and clothing are at a safe distance from any moving parts.
- OIL LEVEL - Check the oil level in the engine. For more information see "Lubrication" under the respective engine's "Owners Manual" or the Maintenance section of this manual.
- AIR CLEANER - Check to ensure element is in good condition and properly installed.
- FUEL SUPPLY - The engines on MBW equipment require an automotive grade of clean, fresh, unleaded gasoline.
- FUEL FILTER - If clogged or damaged, replace.

Starting Engine

For detailed instructions refer to the engine "Owner's Manual".

1. Open fuel valve.
2. Turn engine switch to "ON".
3. Set throttle to idle.



CAUTION



The engine speed must NOT be high enough to engage the clutch.

4. Choke engine if necessary (you may not need to choke a warm engine).
5. Pull starter rope repeatedly until engine starts.
6. Move choke lever to open position.
7. Allow engine to warm up for one or two minutes.

Operating

1. Familiarize yourself with the balance of the rammer before using it in job conditions. Due to the inherent design, the machine is top heavy and could tip over.
2. After the engine warms up, open the throttle fully for normal operation.
3. On uneven terrain, pushing down on the handle will aid climbing ability.



WARNING



Do not bear down (body weight of operator) on the machine.

4. After 3 passes, the rammer may have more kick back, this is an indication that ideal compaction is being reached.

Stopping Engine

1. Move throttle to idle position.
2. Let engine idle for one or two minutes.
3. Turn switch on engine to "STOP" position.
4. Turn off fuel valve.



WARNING



Always stop the engine before:

Adding fuel.

Leaving the equipment unattended for any amount of time.

Before making any repairs or adjustments to the machine.

Lifting and Transporting

1. The unit may be lifted by the handle and engine guard.
2. The unit should be transported laying face down
3. Secure it in place by the handle and shoe. DO NOT lay the unit on its sides or face up during transport.

MAINTENANCE



WARNING



Always exercise the stopping procedure before servicing or lubricating the unit.

After servicing the unit, replace and fasten all guards, shields, and covers to their original positions before resuming operation.



CAUTION



Always verify fluid levels and check for leaks after changing fluids.

Do not drain oil onto ground, into open streams, or down sewage drains.

Maintenance Schedule

SYSTEM	MAINTENANCE	DAILY	EVERY 25 HOURS	EVERY 300 HOURS	YEARLY
Air Cleaner	Check and clean	X			
Engine	Refer to engine operator/owner manual	X			
Hardware	Check and tighten as needed ¹		X		X
In Line Fuel Filter	Replace			X	X
Percussion System	Check oil level	X			
	Change oil ²			X	X
Shockmounts	Check for cracks or deterioration				X
Spark Plug	Replace			X	X

1. Check all hardware after the first 5 hours of use, then follow the maintenance schedule.
2. Change oil in lower unit after the first 50 hours of operation, then follow the maintenance schedule.

Fluid Levels

SYSTEM	FLUID VOLUME	RECOMMENDED OIL
Percussion System	16 oz. (.47 L)	SF SAE 10W-30 Motor Oil
Engine	Refer to engine operator/owner manual	

Engine Maintenance

Refer to the engine owner's manual for maintenance intervals and procedures.

- Check and clean the air cleaner element at least once daily. The air cleaner has a foam pre-cleaner that can be washed.
- Check the engine oil level by removing the dipstick (the engine must be level). The oil level should be between the marks on the dipstick. See the "Check Engine Oil" section of the engine "Owner's Manual" for information.
- See the "Change Engine Oil" section of the engine "Owner's Manual" for information on the oil change intervals.

Engine Speed

Engine speed is factory set according to the speed listed in the Specifications section of this manual. Refer to the engine owners manual for procedure on setting operating speed if necessary.

Checking Percussion System Oil

Refer to Lower Unit Assembly, page 16.

The rammer percussion system and gearbox are lubricated by an oil mist which is formed and carried throughout the rammer by a pumping action in the machine's lower system.

1. Before daily operation, place the rammer on a flat surface and check the oil level in the sight gauge (#9) on the back side of lower unit (#11).

2. If the oil is not visible in the sight gauge, add oil through fill plug on top of gear box, page 14 (#27) as required. See Fluid Levels section of this manual for recommended type of oil.
3. Wait several minutes for oil to run down into lower unit and check oil level in sight gauge again. Be sure not to over fill unit.

Changing Percussion System Oil

Refer to Lower Unit Assembly, page 16.

1. Remove the drain plug (#17) below the sight gauge (#9) on the back of the springbox (#11).
2. Place an oil drain pan behind the shoe and tip the rammer back so the handle is on the ground.

Refer to Gearbox and Lower Unit Assembly, page 18.

3. With the handle still on the ground, remove the six hex head flange screws (#10) holding the cover (#5) to the gearbox (#3).
4. Remove the cover (#5) and cover gasket (#2), from the gearbox (#3).
5. Tip the unit forward and drain any oil into an oil pan.
6. After the oil has drained completely, replace the drain plug.
7. Pour oil as specified from Fluid Level section of this manual into front of gear box. Replace cover gasket, and cover and secure with the six hex head flange screws.

SERVICE

Assembly and disassembly should be performed by a service technician who has been factory trained on MBW equipment. The unit should be clean and free of debris. Pressure washing before disassembly is recommended.

- Prior to assembly, wash all parts in a suitable cleaner or solvent.
- Check moving parts for wear and failure. Refer to the Replacement section in this manual for tolerance and replacement cycles.
- All shafts and housings should be oiled prior to pressing bearings. Also, ensure that the bearings are pressed square and are seated properly.
- All bearings should be replaced when rebuilding any exciter or gearbox.
- All gaskets and seals should be replaced after any disassembly.

Torque Chart

SIZE	GRADE 2	GRADE 5	GRADE 8
1/4-20	49 in·lbs	76 in·lbs	9 ft·lbs
1/4-28	56 in·lbs	87 in·lbs	10 ft·lbs
5/16-18	8 ft·lbs	13 ft·lbs	18 ft·lbs
5/16-24	9 ft·lbs	14 ft·lbs	20 ft·lbs
3/8-16	15 ft·lbs	23 ft·lbs	33 ft·lbs
3/8-24	17 ft·lbs	26 ft·lbs	37 ft·lbs
7/16-14	24 ft·lbs	37 ft·lbs	52 ft·lbs
7/16-20	27 ft·lbs	41 ft·lbs	58 ft·lbs
1/2-13	37 ft·lbs	57 ft·lbs	80 ft·lbs
1/2-20	41 ft·lbs	64 ft·lbs	90 ft·lbs
9/16-12	53 ft·lbs	82 ft·lbs	115 ft·lbs
5/8-11	73 ft·lbs	112 ft·lbs	159 ft·lbs
5/8-18	83 ft·lbs	112 ft·lbs	180 ft·lbs
3/4-16	144 ft·lbs	200 ft·lbs	315 ft·lbs
1-8	188 ft·lbs	483 ft·lbs	682 ft·lbs
1-14	210 ft·lbs	541 ft·lbs	764 ft·lbs
1-1/2-6	652 ft·lbs	1462 ft·lbs	2371 ft·lbs
M 6	3 ft·lbs	4 ft·lbs	7 ft·lbs
M 8	6 ft·lbs	10 ft·lbs	18 ft·lbs
M 10	10 ft·lbs	20 ft·lbs	30 ft·lbs
CONVERSIONS			
in·lbs x 0.083 = ft·lbs			
ft·lbs x 12 = in·lbs			
ft·lbs x 0.1383 = kg·m			
ft·lbs x 1.3558 = N·m			

Service Tools

Part No.	Description
01629	Rubber Test Mat
20260	Springbox Tool
07205	Bellows Installation Tool
07552	Blind Hole Bearing Puller Tool
19950	Service Kit (Robin)
20194	Service Kit (Honda)

Handle Removal

Refer to Handle Assembly, page 20.

1. Turn fuel valve (#11) to the "off" position.
2. Loosen the hose clamp closest to the carburetor and disconnect the fuel line (#9) from the carburetor.
3. Remove the hardware (#20) holding the throttle (#18) to the handle.
4. Disconnect the tachometer (#16) wire running from the engine.
5. Remove four hex head flange screws (#23) and lift the handle free from the rammer.

Engine Removal

Note: It is not necessary to remove the handle to take the engine off the machine

Refer to Engine Assembly, page 22.

Robin EH12 Engine

1. Follow steps 1 through 4 under "Handle Removal."
2. Remove the two hex head cap screws (#2) and lock washers (#4) that secure the bottom of the engine to the spacer plate. Then, while supporting the engine, remove the two hex nuts (#3) and lock washers (#4) securing the top of the engine to the spacer plate.
3. Remove the engine from the spacer plate.

Honda GX100 Engine

1. Follow steps 1 through 4 under "Handle Removal."
2. Support the engine and remove the four flange nuts (#13) securing the engine to the gearbox.
3. Remove the engine from the machine.

Centrifugal Clutch

Refer to Engine Assembly, page 22

1. Remove jam nut (#17) and key (10). Slide clutch (#9) off engine crank.
2. Carefully insert woodruff key (#10) making sure key remains aligned with keyway.
3. Apply anti seize to engine shaft and slide clutch onto shaft.
4. Reinstall jam nut with medium strength thread locker and tighten to 60 ft.-lbs.

Gearbox Removal

Note: It is necessary to remove the Handle and the Engine to remove the Gearbox. It is easier to reassemble the gearbox if the handle and engine are removed.

1. If removing handle & engine refer to Handle Removal and Engine Removal sections of this manual.

Refer to the Gearbox and Lower Unit Assembly, page 18

2. Remove the hex flange screws (#10) holding the cover to the gearbox.



CAUTION

NOTE: There may be oil in the gearbox. Tip the unit back when removing the cover from the gearbox.

3. Tip the unit forward and drain any oil into an oil pan.
4. Remove the retaining ring (#7) from piston. Thread a 5/16-18 screw into the piston pin (#6) and remove the piston pin. (See Fig 1)
5. Remove the hex head cap screws and lock washers (#8 & #9) holding the gearbox to the lower system.
6. Remove the gearbox assembly (#3) from the lower system. (See Fig 2)

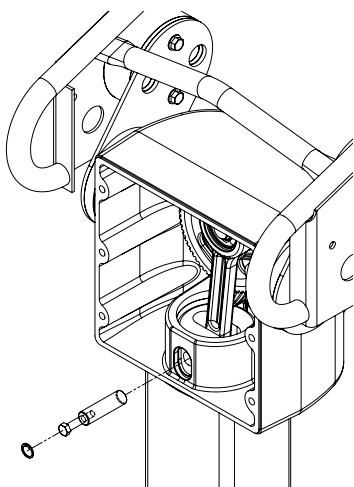

Fig 1

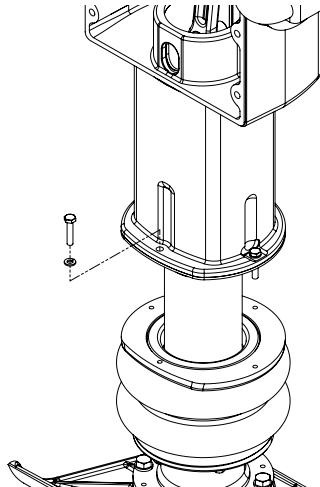

Fig 2

Crank Gear Removal

Refer to Gearbox Assembly, page 14.

1. Slip a retaining ring pliers through the slot opening in the crank gear (#20) and remove the retaining ring (#10).
2. Remove the SAE plug (#19) from the rear of the gearbox. Use a 3/8 in. (10mm) dia steel rod to press the crank gear out of the gearbox.
3. Remove the small retaining ring (#9) from the front of the crank gear (#20) and remove the connecting rod (#5).
4. Remove the retaining ring (#1) from the back of the crank gear. Remove the ball bearing (#2) using a bearing puller.

Pinion Removal

1. Remove the retaining ring (#4) from inside of the gearbox and press out the pinion (#21).
2. If the retaining ring is pinched in its groove, tap on the drum side of the pinion. This will relieve the pressure on the retaining ring.
3. Pry out the oil seal (#11) and discard. Remove the retaining rings (#10 & #18). Use a bearing puller to remove the ball bearings (#2 & #22).

Breather Assembly

1. Remove the hex head cap screw (#28) from the top of the breather assembly. Remove the plain washer, cap and filter (#29, #17, #15).
2. Use a pipe wrench to remove the breather tube (#16).



CAUTION

Do not disassemble the breather assembly.

Slide Bearing Removal

1. Remove the slide bearings support & slide bearing (#24, #25) by pulling them out of the housing guide tube.



CAUTION

Do not scratch or gouge the housing guide tube walls.

Lower Unit

Note: The lower unit can be separated from the drive unit (engine, gearbox and handle) without going through the complete disassembly procedure. If the lower system has not already been separated, follow the "Gearbox Removal" instruction.

Bellows and Shoe

Refer to Lower Unit Assembly, page 16.

Shoe and Springbox Removal

1. Drain the oil by removing the drain plug (#17). Tilt the lower unit to the side until all of the oil is drained out.
2. Remove the six hex head cap screws (#19) and lock washers (#20) from the top flange of the spring box (#11). Remove the bellows and clamping rings (#6, #7 & #8).
3. Remove the six hex head cap screws (#20) and lock washers (#21) from the bottom flange of the spring box. Remove the shoe (#10).

Springbox



CAUTION



Observe the warning label on the Springbox Cover. Springbox contains springs under high compression. Follow the next steps very carefully.

1. Flip Springbox Assembly upside down. Insert two springbox tools (MBW #20260) into the bottom of the springbox cover (tools should be 180 degrees apart). Run the nuts that come with the tools down snug against the Cover. Remove the flat head socket screws holding the cover to the springbox. (See Fig 3)

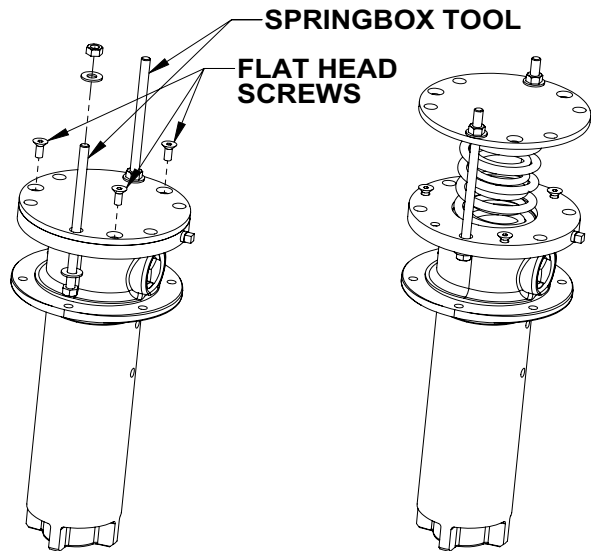

FIG. 3

FIG. 4

2. While holding the bottom of the tool (#20260) from turning, slowly and evenly back off the nuts on the cover (#3). The tools and the cover can be removed when spring tension has been relieved. (See Fig 4)

Refer to Lower Unit Assembly, page 16.

3. Remove the o-ring (#4) from the cover (#3).
4. The lower springs (#1 & #2) can be removed from the springbox.

5. Place a drift pin or steel rod through the piston hole in the ram head (#12). Use this to hold the ram head from turning while removing the nut (#5). Remove and discard the elastic nut.
6. Remove the spring separator (#15), slide bearing (#16) and upper springs (#1 & #2).
7. Remove retaining ring (#14) and ram shaft slide bearing (#13).

Assembly Instructions



CAUTION



Prior to assembly wash all parts in a suitable cleaner or solvent.

Check moving parts for wear and failure. Refer to Parts Replacement and Tolerance Chart for tolerances and replacement cycles.

Replace all seals and gaskets at every overhaul or disassembly.

For torque settings other than those listed, see torque chart.

All shafts and housings should be oiled prior to pressing bearings in. Also, ensure that bearings press in square and seat properly.

Gearbox Assembly

Refer to Gearbox Assembly, page 14.

1. Press the small ball bearing (#22) into the housing from the back. Secure with a retaining ring (#18).
2. Press the large ball bearing (#2) into the housing from the back. Secure with a retaining ring (#10).
3. Press a new oil seal (#11) into the gearbox. Make sure the oil seal is pressed in straight.
4. Lightly oil the lip of the oil seal and the shaft portion of the pinion carefully press the pinion (#21) into the gearbox. Do not use excessive pressure to seat the pinion.
5. Install retaining ring (#4) into the pinion from inside the gearbox.
6. Press in the needle bearing (#6) inside the gearbox. Bearing must be pressed in with the numbers and letters facing up.
7. Place the retaining ring (#10) over the large shaft of the crank gear (#20). Press the ball bearing (#2) onto the crank gear.
8. Install retaining ring (#1) to secure the ball bearing.
9. Press bushing (#7) into connecting rod (#5).

10. Press the ball bearing (#3) into connection rod (#5) and secure with internal snap ring (#8).
11. Insert connecting rod assembly (#5) onto crank gear (#20), and secure with external retaining ring (#9).
12. Press the crank gear assembly into the gearbox. Install the snap ring (#10) using a retaining ring pliers inserted through the slot in the crank gear.
13. Install the SAE (#19) plug. Do not over tighten.
14. Replace the breather assembly (#14), filter, cap, and plain washer. Apply Loctite #242 to the threads of the hex head cap screw (#28) and install.
15. Slide bearing support (#24) into housing guide tube. Align tabs on bearing support to fit sides of rib in guide tube on engine side of housing.
16. Push slide bearing (#25) into bearing support. Align hole on top of slide bearing with opening in gear box.

Lower Unit Assembly

Refer to Lower Unit Assembly, page 16.

1. Install slide bearing (#13) into top of spring box (#11) and secure with retaining ring (#14).
2. Install the upper springs (#1,#2) into the springbox (#11).
3. Install the ram head (#12), spring separator (#15) and slide bearing (#16).
4. Secure with a new elastic stop nut (#5) torqued to 100 ft. lbs (135 Nm).
5. Install the lower springs (#1,#2).
6. Lightly grease the o-ring groove in the cover (#3) before installing a new o-ring (#4).
7. Use the two springbox tools (MBW #20260) to draw the cover down onto the springbox.
8. Install three flat head socket screws (#18) and torque to 8 ft. lbs (11Nm).



CAUTION



The springbox WARNING DECAL should be clean and highly visible. If it is not, the old decal should be completely removed and replaced.

9. Assemble shoe (#10) to bottom of spring box with hex head cap screws (#22) and lock washers (#21). Orient the sight gauge (#9) so it points to the back side of the machine.
10. Install the bellows (#7) and clamping rings (#6 & #8) to the spring box and secure with six hex head cap screws (#19) and lock washers (#20). Torque to 9 ft. lbs (12 Nm).

Gearbox & Lower Unit Assembly

Refer to Gearbox and Lower Unit Assembly, page 18.

1. Before installing the gearbox to the lower assembly, apply Loctite #598 or equivalent silicone to the bottom of the gearbox (#3). Press the oil seal spacer (#1) onto the bottom of the gearbox.
2. Slide the gearbox assembly (#3) onto the lower assembly (#4). Secure using four hex head cap screws (#8) with lock washers (#9) torqued to 12 ft. lbs (16Nm).
3. Align the connecting rod with the piston and install the wrist pin (#6) Install the retaining ring (#7) to secure wrist pin in place.
4. Place a new gasket (#2) over the face of the gearbox.
5. Secure the cover to the gearbox using the hex flange head screws from the previous step. Be sure the bolts pass through the holes in the gasket. Tighten the flange screws equally and torque to 8 ft. lbs (11Nm). The gasket will compress slightly after initial tightening. Retorque the bolts after 5 minutes.
6. If the handle mounting brackets were removed, apply Loctite #242 to the four hex head flange screws and assemble handle bracket see page 20.
7. Refill percussion unit with oil per procedure in Maintenance section.

Parts Replacement Cycles and Tolerances

Bearings	Replace anytime a bearing is rough, binding, discolored or removed from housing or shaft.
Bellows	Replace when they are worn, cracked, or to the point of leaking.
Clutch	Replace clutch if the shoe and springs show signs of heat damage or if the clutch engages below 2000 rpm.
Crank Gear	Replace if teeth are cracked or if they become sharp.
Engine Components	Refer to your engine manufacturer's Owner's Manual.
Slide Bearings (Gear Box)	Replace if a 0.025" (0.635mm) feeler gauge can be slid between the spring box and guide tube.
Hardware	Replace any worn or damaged hardware as needed. Replacement hardware should be grade 5 and zinc plated unless otherwise specified.
Pinion	Replace if teeth are cracked or if they become sharp. Replace if the drum is scored or gouged deeper than 0.03" (.76mm).
Slide Bearing (Spring Separator)	Replace if a 0.025" (0.635mm) feeler gauge can be slid between the springbox and the piston.
Piston Pin	Replace if the outside diameter is less than 0.620" (15.75mm)
Slide Bearing (Ram Shaft)	Replace if less than .100 thick or visibly damaged.
Safety Decals	Replace if they become damaged or illegible.
Seals & Gaskets	Replace if a leak is detected and at every overhaul or teardown.
Springs	If a flat spot on the side of a spring is greater than 0.09 in (2 mm) or the free length is less than 6.75 in (171 mm), replace all .

This page intentionally left blank

REPLACEMENT PARTS

The warranty is stated in this book on page 18. Failure to return the Warranty Registration Card renders the warranty null and void.

MBW has established a network of reputable distributors/dealers with trained mechanics and full facilities for maintenance and rebuilding, and to carry an adequate parts stock in all areas of the country. Their sales engineers are available for professional consultation. If you cannot locate an MBW distributor in your area, contact MBW or one of our Sales Branches listed below.

When ordering replacement parts, be sure to have the following information available:

- Model and Serial Number of machine when ordering MBW parts
- Model and Serial Number of engine when ordering engine parts
- Part Number, Description, and Quantity
- Company Name, Address, Zip Code, and Purchase Order Number
- Preferred method of shipping

REMEMBER - You own the best! If repairs are needed, use only MBW parts purchased from authorized MBW distributors.

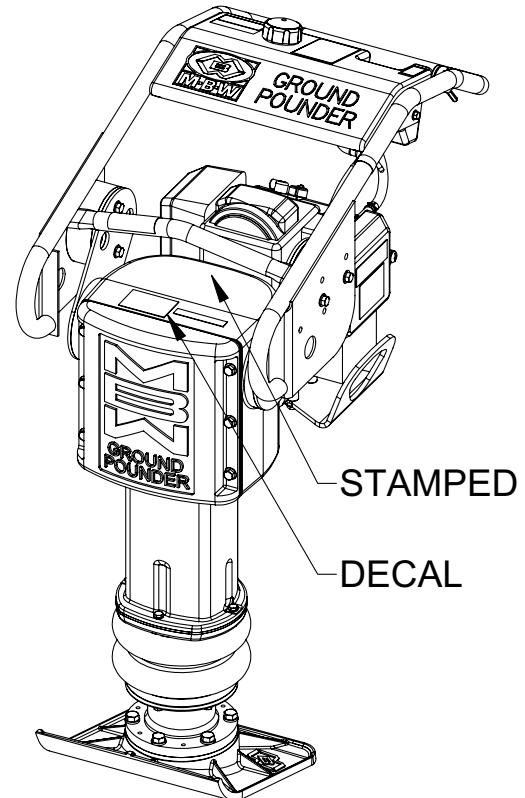

The unit's serial number can be found in the following locations:

- The serial number decal is located on the top of the gearbox.
- The serial number is also stamped on the top of the gearbox.

Write Model Number here

Write Serial Number here

Contact Information

MBW, Inc.
250 Hartford Rd • PO Box 440
Slinger, WI 53086-0440
Phone: (262) 644-5234
Fax: (262) 644-5169
Email: mbw@mbw.com
Website: www.mbw.com

MBW (UK) Ltd.
Unit 6, Bradley Fold Trading Estate
Radcliffe Moor Road
Bolton BL2 6RT, England
Phone: 01204 387784
Fax: 01204 387797

MBW FRANCE S.A.R.L.
Z.A. d'Outreville
11 rue Jean Baptiste Néron,
60540 BORNEL
FRANCE
Teléfono: +33 (0) 3 44 07 15 96
Fax: +33 (0) 3 44 07 41 28
Correo electrónico: mbwfrance@free.fr

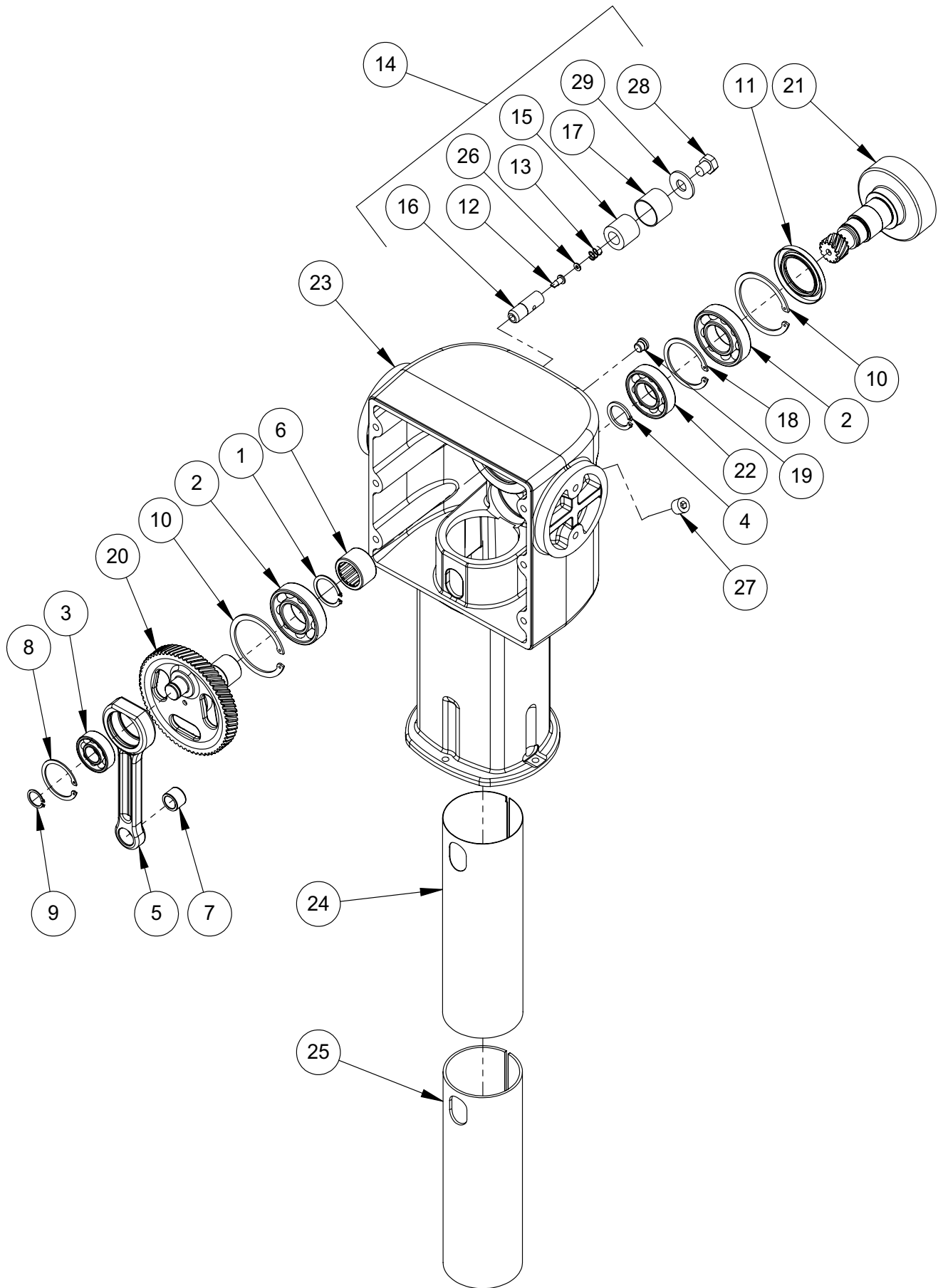

Gearbox Assembly

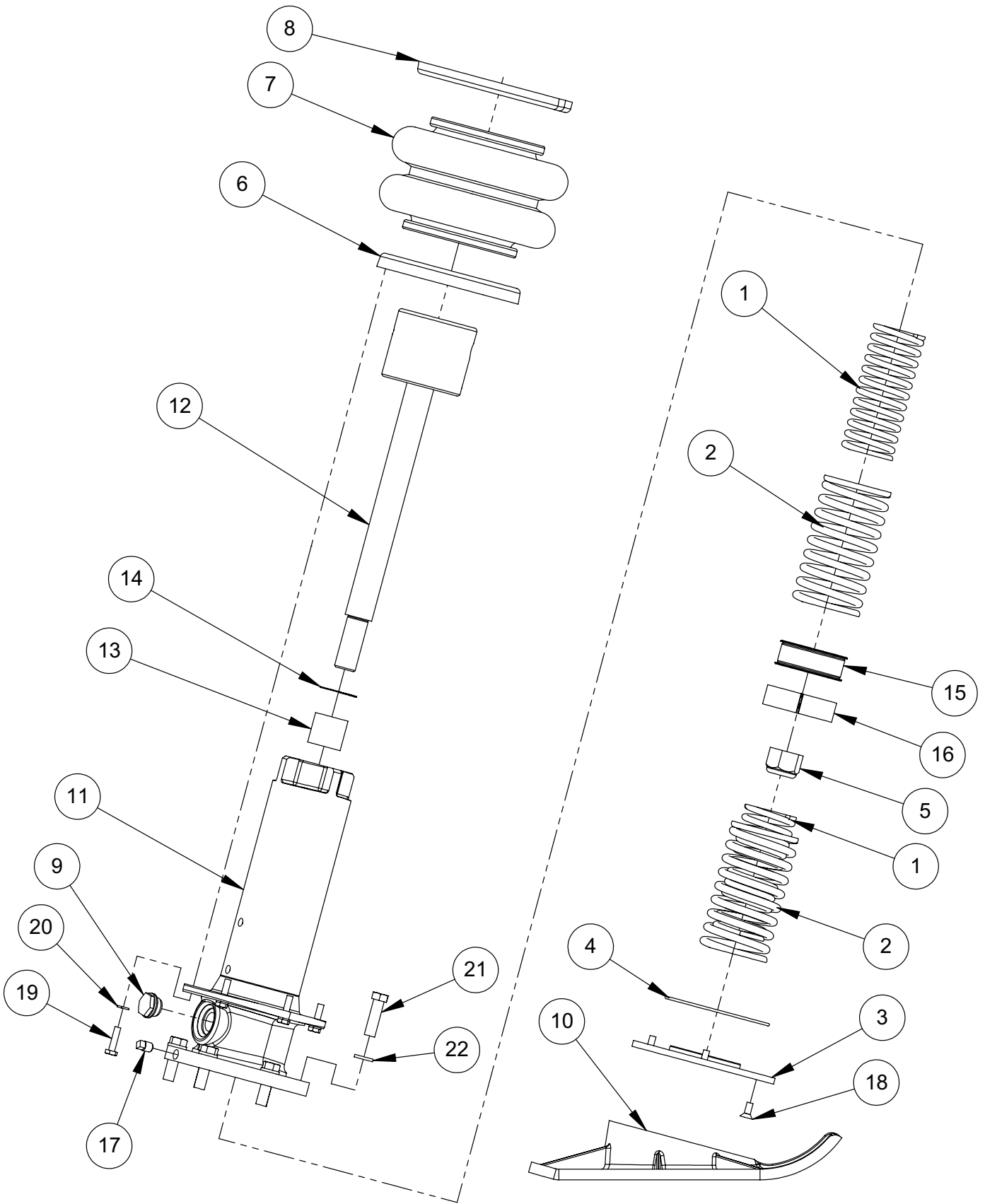

Lower Unit Assembly

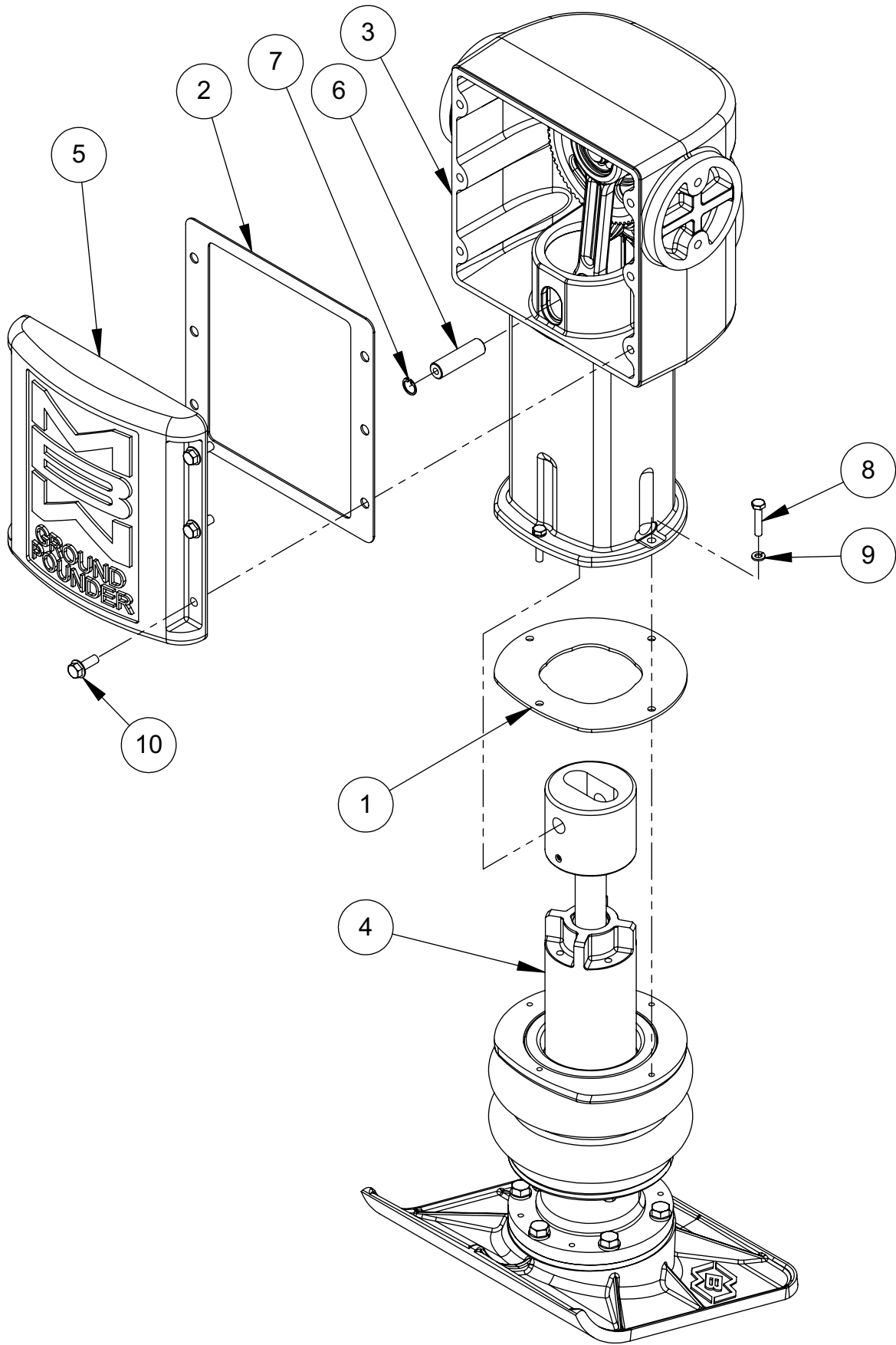

Gearbox and Lower Unit Assembly

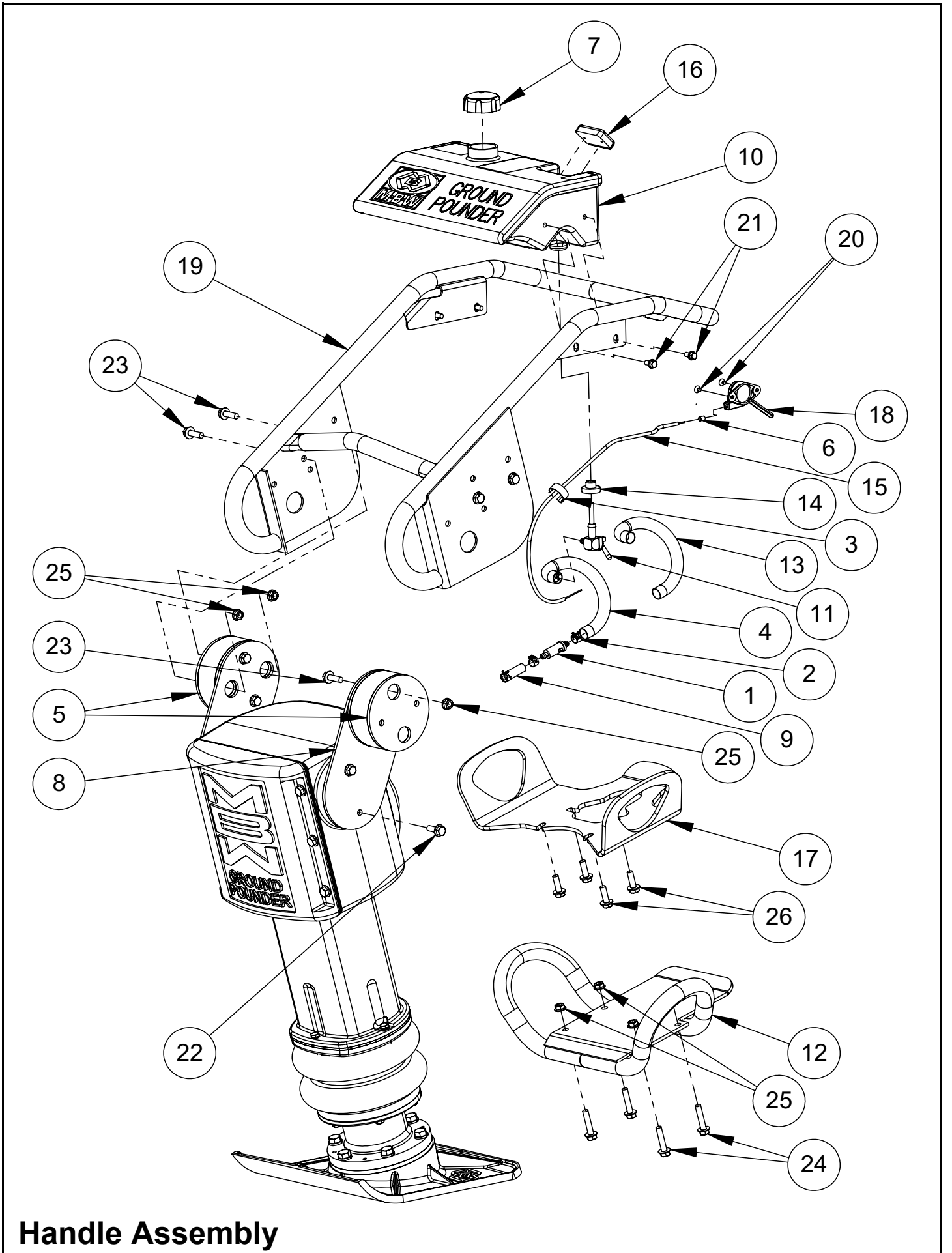

Handle Assembly

ITEM	PART NO.	DESCRIPTION	QTY
1.	01045	FILTER, FUEL	1
2.	01052	CLAMP, HOSE, 1/2"	4
3.	01145	CLAMP, CABLE	1
4.	01034	HOSE, FUEL, 1/4" X 6" (482H ONLY)	1
	02293	HOSE, FUEL, 1/4" X 13" (482R ONLY)	1
5.	07351	TORSION MOUNT	2
6.	07916	FERRULE, THROTTLE LEVER	1
7.	14714	CAP, 1-3/4" (for engines with diaphragm carburetor)	1
	16666	CAP, 1-3/4" (for engines with float carburetor)	1
8.	14965	BRACKET, MOUNTING, HANDLE	2
9.	15183	HOSE, FUEL, 1/4" X 1-1/2"	1
10.	16303	TANK, FUEL	1
11.	16414	VALVE, FUEL	1
12.	16567	GUARD, ENGINE (ROBIN ONLY)	1
13.	16568	SLEEVING, POLY x 14" (ROBIN ONLY)	1
	17439	SLEEVING, POLY x 7" (HONDA ONLY)	1
14.	16586	GROMMET, 1/2"	1
15.	16668	CABLE, THROTTLE (ROBIN ONLY)	1
	19899	CABLE, THROTTLE (HONDA ONLY)	1
16.	17602	TACHOMETER & HOURMETER KIT	
17.	18527	GUARD, ENGINE (HONDA ONLY)	1
18.	18742	THROTTLE, RACHET STYLE	1
19.	18877	GUIDE HANDLE	1
20.	F032402FSS	FLAT HEAD SCREW, #10-24 X 1/4" ZP	2
21.	F042004HCS	HEX HEAD CAP SCREW, 1/4-20 X 1/2 ZP	4
22.	F051807FWS	FLANGE SCREW, 5/16-18 X 7/8 ZP	4
23.	F051808FWS	FLANGE SCREW, 5/16-18 X 1 ZP	8
24.	F051812FWS	FLANGE SCREW, 5/16-18 X 1-1/2 ZP	4
25.	F0518FN	NUT, FLANGE, 5/16-18 ZP	12
26.	M08C025FWS	FLANGE SCREW M8-1.25 X 25MM ZP (480H/481H ONLY-PLATE STYLE GUARD)	4
		ITEMS NOT SHOWN:	
	16575	WIRE CLAMP, ADHESIVE BACKED (NOT SHOWN)	3
	07592	TERMINAL, SCOTCHLOK SPLICE (NOT SHOWN)	1
			1

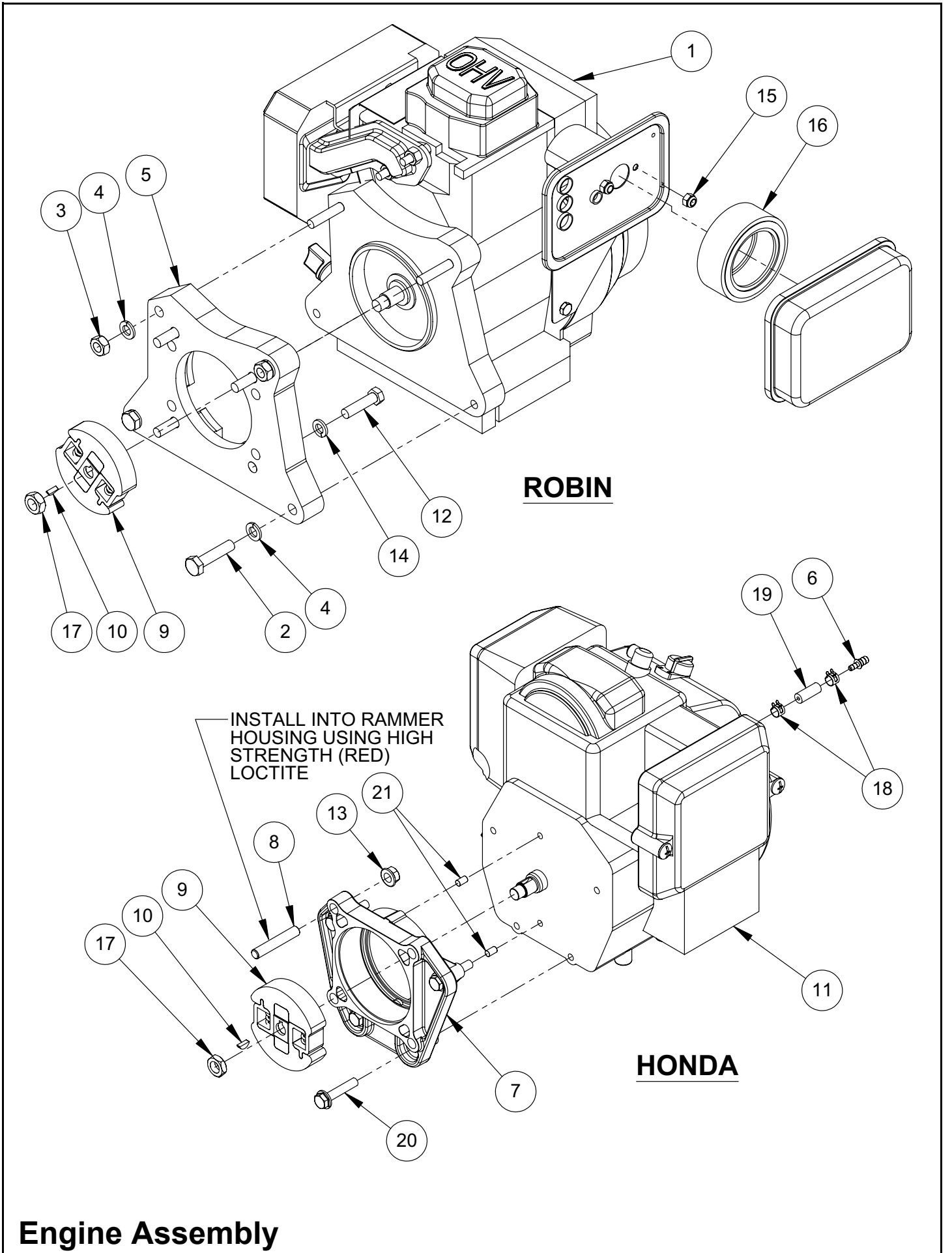

ITEM	PART NO.	DESCRIPTION	QTY
1.	14872	ENGINE, ROBIN EH12 (Includes items: 5, 9,10,17)	1
2.	15068	HHCS, M10-1.5 X 45MM	2
3.	15184	NUT, HEX M10-1.5 PITCH	2
4.	15185	LOCKWASHER, M10	4
5.	15226	ADAPTER, ENGINE (ROBIN EH12)	1
6.	17217	REDUCER, BARBED	1
7.	17406	ADAPTER, ENGINE (HONDA GX100)	1
8.	17432	STUD (HONDA ONLY)	4
9.	18055	CLUTCH, KIT (INCLUDES ITEMS: 10 & 17)	1
10.	18053	KEY, WOODRUFF, METRIC 4 X 13	1
11.	18554	HONDA GX100 ENGINE, DIAPHRAGM STYLE (Includes items: 7,9,10,17,20 & 21)	1
12.	F061614HCS	HHCS, 3/8-16 X 1-3/4 GR5 ZP	4
13.	F0616FN	NUT, FLANGE 3/8-16 ZP	4
14.	F06LW	LOCKWASHER, 3/8 ZP	4
15.	J0176060020	NUT, SELF LOCKING	2
16.	J2523260207	ELEMENT AIR CLEANER (ROBIN EH12)	1
17.	Q17211ZL8023 M12CHJN	ELEMENT AIR CLEANER (HONDA GX100) JAMNUT, HEX, 12MM-1.25 ZP	1
18.		CLIP, FUEL LINE (Not provided by MBW Inc.)	2
19.		FUEL LINE, 3/16 ID X 1" LONG (Not provided by MBW Inc.)	1
20.		HEX HEAD FLANGE SCREW, M8-1.25 X 40MM (Not provided by MBW Inc.)	4
21.		PIN, DOWEL, 6MM X 10MM (Not provided by MBW Inc.)	2
		KITS:	
	20194	SERVICE KIT HONDA RAMMER: #01045 IN-LINE FUEL FILTER	
		#15667 HOUSING COVER GASKET #16414 FUEL VALVE	
		#16586 GROMMET, FUEL VALVE #19951 OIL, 1-QUART	
		Q17211ZL8023 AIR CLEANER ELEMENT (ITEM 16) Q9805655777 SPARK PLUG CR5HSB	
	19950	SERVICE KIT ROBIN RAMMER	
		#01045 IN-LINE FUEL FILTER #15667 HOUSING COVER GASKET	
		#16414 FUEL VALVE #16586 GROMMET, FUEL VALVE	
		#19951 OIL, 1-QUART J2523260207 AIR CLEANER ELEMENT (ITEM 16)	
		J0650140100 SPARK PLUG, NGK B-6ES	

WARRANTY

WHAT DOES THIS WARRANTY COVER? MBW, Incorporated (MBW) warrants each New Machine against defects in material and workmanship for a period of twelve (12) months. "New Machine" means a machine shipped directly from MBW or authorized MBW dealer to the end user. This warranty commences on the first day the machine is sold, assigned to a rental fleet, or otherwise put to first use.

MBW warrants each Demonstration Machine against defects in material and workmanship for a period of six (6) months. "Demonstration Machine" means a machine used by MBW or its agents for promotional purposes. This warranty commences on the first day the machine is sold, assigned to a rental fleet, or otherwise put to first use.

This warranty covers the labor cost for replacement or repair of parts, components, or equipment on New Machines or Demonstration Machines, and MBW shall pay labor costs at MBW's prevailing rate to affect the warranted repair or replacement. MBW reserves the right to adjust labor claims on a claim-by-claim basis.

This warranty covers the shipping cost of replacement parts, components, or equipment via common ground carriers from MBW to an authorized MBW dealer. Air freight is considered only in cases where ground transportation is not practical.

MAY THIS WARRANTY BE TRANSFERRED? This warranty is non-transferable and only applies to the original end user of a new machine or demonstration machine.

WHAT DOES THIS WARRANTY NOT COVER?

1.This warranty does not cover any Used Equipment. "Used Equipment" means any MBW machine or equipment that is not a New Machine or a Demonstration Machine. All Used Equipment is sold **AS IS/WHERE IS WITH ALL FAULTS**.

2.This warranty does not cover any New Machine, Demonstration Machine, or their equipment, parts, or components altered or modified in any way without MBW's prior written consent. This warranty does not cover the use of parts not specifically approved by MBW for use on MBW products. This warranty does not cover misuse, neglect, shipping damage, accidents, acts of God, the operation of any New Machine or Demonstration Machine in any way other than recommended by MBW in accordance with its specifications, or any other circumstances beyond MBW's control. This warranty does not cover any New Machine or Demonstration Machine repaired by anyone other than MBW factory branches or authorized MBW distributors.

3.This warranty does not cover, and MBW affirmatively disclaims, liability for any damage or injury resulting directly or indirectly from design, materials, or operation of a New Machine or Demonstration Machine or any other MBW product. MBW's liability with respect to any breach of warranty shall be limited to the provisions of this document and in no event shall exceed an amount equal to the purchase price of the New Machine or Demonstration Machine purchased from MBW.

4.This warranty does not cover engines, motors, and other assemblies or components produced by other manufacturers and used on a New Machine or Demonstration Machine, as said engines, motors, and other assemblies or components may have warranties provided by the manufacturer thereof. This warranty does not apply to consumable items, such as v-belts, filters, trowel and screed blades, seals, shock mounts, batteries, and the like, all of which are sold **AS IS/WHERE IS WITH ALL FAULTS**.

5.This warranty does not cover the cost of transportation and other expenses which may be connected with warranty service but not specifically mentioned herein.

6.This warranty does not cover any updates to any New Machine, Demonstration Machine, or any other MBW product. MBW reserves the right to improve or make product changes without incurring any obligation to update, refit, or install the same on New Machines or Demonstration Machines previously sold.

WHAT MUST YOU DO TO OBTAIN WARRANTY COVERAGE? Each New Machine or Demonstration Machine is accompanied by a Warranty Registration Card. You must sign, date, and return the Warranty Registration Card to the place of origin of the New Machine or Demonstration Machine, either to MBW, Inc. at P.O. Box 440, Slinger, Wisconsin 53086, MBW (UK), Ltd. at Units 2 & 3 Cochrane Street, Bolton BL3 6BN, United Kingdom or MBW FRANCE SARL at ZA D'Outreville, 5 Rue Jean Baptiste Neron, Bornel 60540 France, within ten (10) days after purchase, assignment to a rental fleet, or first use. This signed warranty card is the buyer's affirmation that he has read, understood, and accepted the warranty at the time of purchase. Failure to return the warranty card as specified herein renders the warranty null and void. In order to receive warranty coverage consideration, warranty claims must be submitted within thirty (30) days after the New Machine or Demonstration Machine fails. Warranty claims must be submitted to MBW, Inc., MBW (UK), Ltd. or MBW FRANCE SARL, and written authorization for the return of merchandise or parts under the warranty must be obtained before shipment to MBW.

WHAT WILL MBW DO? MBW's obligation under this warranty is limited to the replacement or repair of parts for a New Machine or Demonstration Machine at MBW factory branches or at authorized MBW distributors, and such replacement or repair is the exclusive remedy provided hereunder. Labor must be performed at an authorized MBW distributor. MBW reserves the right to inspect and render a final decision on each warranty case, and MBW's repair or replacement is solely within the discretion of MBW.

IT IS EXPRESSLY AGREED THAT THIS SHALL BE THE SOLE AND EXCLUSIVE REMEDY UNDER THIS WARRANTY. UNDER NO CIRCUMSTANCES SHALL MBW BE LIABLE FOR ANY COSTS, LOSS, EXPENSE, DAMAGES, SPECIAL DAMAGES, INCIDENTAL DAMAGES, OR PUNITIVE DAMAGES ARISING DIRECTLY OR INDIRECTLY FROM THE USE OF THE NEW MACHINE OR DEMONSTRATION MACHINE WHETHER BASED UPON WARRANTY, CONTRACT, NEGLIGENCE, STRICT LIABILITY, OR ANY OTHER LEGAL THEORY.

THE FOREGOING WARRANTY IS EXPRESSLY IN LIEU OF ALL OTHER WARRANTIES, EXPRESS OR IMPLIED, INCLUDING THE WARRANTIES OF MERCHANTABILITY, FITNESS FOR USE, AND FITNESS FOR A PARTICULAR PURPOSE, AND ALL OTHER OBLIGATIONS OR LIABILITY ON MBW'S PART. MBW NEITHER ASSUMES NOR AUTHORIZES ANY OTHER PERSON TO ASSUME ON BEHALF OF MBW ANY OTHER LIABILITY OR WARRANTY IN CONNECTION WITH THE SALE OR SERVICE OF ANY NEW MACHINE, DEMONSTRATION MACHINE , OR ANY OTHER MBW PRODUCT.

EXTENDED RAMMER WARRANTY - MODELS R422, R442, R482 & R483.

This extended warranty commences on the last day of MBW's standard, one year, "limited warranty" and runs for an additional four years (48 months). This extended warranty is limited to part replacement and shipping costs of rammer **bellows and non-metallic slide bearings only**. This extended warranty does not cover labor, down time, or any other cost beyond that of component replacement and freight. This extended warranty is subject to all limitations set fourth in MBW's "limited warranty", above.

