



VIBRATORY PLATES



QUALITY ENGINEERED. QUALITY BUILT. QUALITY SURVIVES.

WWW.MBW.COM

SINGLE DIRECTION

FEATURES

MBW's advancements in vibratory plates have revolutionized the field over the past 50 years. Each model offers a unique combination of frequency, centrifugal force, amplitude and mass that have doubled productivity, dramatically reduced maintenance, and extended product life.

- Unsurpassed exciter quality including extra heavy duty housings, oversized application matched bearings, and an oil mist lubrication system to withstand high operating temperatures.
- Application matched quality shock mounts and double isolated guide handles.

1000 SERIES



This series of economical vibratory plates, the **12**, **15** & **18**, are portable, and offer outstanding compaction performance. A patented suspension system places shock mounts in a predominantly shear mode at the high amplitude front end of the plate and a predominantly compressive mode at the low amplitude trailing end of the plate. This system reduces hand arm vibration and also better isolates all upper mass components, including the engine, from vibrations produced by the machine's exciter. With amplitudes up to .067 inches, centrifugal force up to 2780 lbs and travel speeds to 83 feet per minute these plates are ideal in confined areas of granular soils including

1000 SERIES

sands and gravel.

These lightweight plates weighing 133 lbs (60 kg) to 165 lbs (75 kg) are easy to lift and maneuver about the job site. Accompanied by intense vibration, this series of plates are ideally suited as an economical alternative for small to medium compaction applications.

- Standard with Honda engine and lift cage
- One piece exciter with self cleaning open base plate design
- Optional wheel kit
- Optional UHMW paving pad for placing interlocking paving stone/brick/block



OPTIONAL WHEEL KIT



OPTIONAL UHMW PAD

MODEL	GP12	GP15	GP18
Plate Size WxL	13 x 22.5 in (33 x 57 cm)	16 x 22.5 in (40 x 57 cm)	18 x 22.5 in (46 x 57 cm)
Operating Weight	133 lbs (60 kg)	142 lbs (64 kg)	163 lbs (74 kg)
Engine	Honda GX120	Honda GX120	Honda GX120
Amplitude	.058 in (1.47 mm)	.054 in (1.37 mm)	.067 in (1.72 mm)
Centrifugal Force**	1920 lbs (8.5 kN)	2000 lbs (8.9 kN)	2780 lbs (12.3 kN)
Exciter Speed	5240 vpm	5350 vpm	5240 vpm
Compaction Depth*	Up to 10 in (25 cm)	Up to 10 in (25 cm)	Up to 10 in (25 cm)
Travel Speed	up to 83 ft/min (25 m/min)	up to 68 ft/min (21 m/min)	up to 75 ft/min (23 m/min)
Compaction Area	5395 ft ² /hr (501 m ² /hr)	5440 ft ² /hr (505 m ² /hr)	6750 ft ² /hr (627 m ² /hr)

* Clean sand, optimum moisture. MBW recommends that lifts not exceed 12".

** Centrifugal Force is not a measure of compaction performance.

() Metric Measurements. Specifications subject to change without notice.

MODEL	AP12	AP15	AP18
Plate Size WxL	13 x 22.5 in (33 x 57 cm)	16 x 22.5 in (40 x 57 cm)	18 x 22.5 in (46 x 57 cm)
Operating Weight	No Water 134 lbs (61 kg) Full Water 152 lbs (69 kg)	No Water 143 lbs (65 kg) Full Water 161 lbs (73 kg)	No Water 165 lbs (75 kg) Full Water 183 lbs (83 kg)
Engine	Honda GX120	Honda GX120	Honda GX120
Amplitude	.058 in (1.47 mm)	.054 in (1.37 mm)	.067 in (1.72 mm)
Centrifugal Force**	1920 lbs (8.5 kN)	2000 lbs (8.9 kN)	2780 lbs (12.3 kN)
Exciter Speed	5240 vpm	5350 vpm	5240 vpm
Compaction Depth*	Up to 10 in (25 cm)	Up to 10 in (25 cm)	Up to 10 in (25 cm)
Travel Speed	up to 83 ft/min (25 m/min)	up to 68 ft/min (21 m/min)	up to 75 ft/min (23 m/min)
Compaction Area	5395 ft ² /hr (501 m ² /hr)	5440 ft ² /hr (505 m ² /hr)	6750 ft ² /hr (627 m ² /hr)
Water Tank Capacity	2.3 gal (8.7 l)	2.3 gal (8.7 l)	2.3 gal (8.7 l)

* Clean sand, optimum moisture. MBW recommends that lifts not exceed 12".

** Centrifugal Force is not a measure of compaction performance.

() Metric Measurements. Specifications subject to change without notice.

SINGLE DIRECTION

2000 SERIES



MBW's AP2000 was the first vibratory plate compactor specifically designed for asphalt applications. Frequency, amplitude, centrifugal force and mass are all established at optimal levels for maximum productivity on asphalt.

Further, the mechanical construction of the AP2000 is specific to this very demanding application.

Stress relieved steel plates provide long wear. Aluminum exciter housing dissipates heat rapidly while lubricants preserve bearing and seal integrity.



The AP2018 is a variation of the AP2000 without a roll cage and with a smaller water tank. These adjustments result in a working height of 18" for use in height restricted applications.

The GP2000 is a permutation of the AP2000 where frequency, amplitude, centrifugal force and mass are adjusted to provide optimal productivity in the compaction of sands and gravel. The GP2000 is capable of achieving excellent densities on lifts of granular soils up to 12" (30 cm)*. All 2000 Series vibratory plates come standard with a Honda engine.



MODEL	AP2000	AP2018	GP2000
Plate Size WxL	20 x 22 in (51 x 56 cm)	20 x 22 in (51 x 56 cm)	20 x 22 in (51 x 56 cm)
Operating Weight	No Water 168 lbs (76 kg)	No Water 168 lbs (76 kg)	165 lbs (75 kg)
	Full Water 193 lbs (88 kg)	Full Water 178 lbs (81 kg)	
Engine Options	Honda GX160		Honda GX160
Amplitude (No Water)	.082 in (2.08 mm)		.083 in (2.11 mm)
Centrifugal Force**	2475 lbs (11 kN)		3250 lbs (14.5 kN)
Exciter Speed	4400 vpm		5050 vpm
Compaction Depth*	Up to 12 in (31 cm)		Up to 12 in (31 cm)
Travel Speed	up to 90 ft/min (27 m/min)		up to 120 ft/min (37 m/min)
Compaction Area	9000 ft ² /hr (836 m ² /hr)		12000 ft ² /hr (1115 m ² /hr)
Water Tank Capacity	3 gal (11.3 l)	1 gal (4.0 l)	N/A



OPTIONAL WHEEL KIT



OPTIONAL UHMW PAVING PAD FOR INTERLOCKING PAVING BLOCKS

THE HEART AND SOUL

of our machines are their rugged, hard hitting exciters. Our exciters include an extra **heavy duty housing** with maximum surface area for heat dissipation and strength, and **ductile eccentric shafts** that are precision ground to preserve bearing tolerances. The **bearings are carefully matched** in design, tolerance and type for high temperature vibratory applications and **custom lubricants** with elevated flash points. Nowhere in the world will you find a stronger or more dependable driving force behind a vibratory plate.

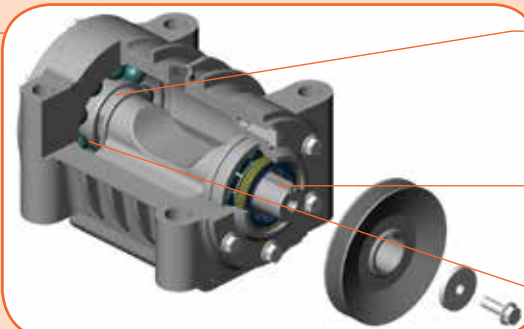

HEAVIEST BEARINGS

in the industry to maintain performance and minimize down time

PRECISION MACHINED SHAFT

to maintain critical bearing tolerances

LUBRICANTS

for high temperature applications

SINGLE DIRECTION

3000 SERIES



THE GP3550 is a high production compactor that will run decades with reasonable maintenance. The deck features a full roll cage as standard equipment with provisions for a water tank for asphalt compaction on the AP3550. Both models provide reduced hand/arm vibration, full roll cage protection, enhanced amplitude, faster travel speed and updated yet rugged appearance.



The GP3000-15 is ideal for confined work areas, such as sidewalk, curb and gutter, and narrow trenches. This specialty plate is not a lightweight compactor. Its operating weight is over 200 lbs. (91 kg) and produces compaction depths up to 16 in. (41 cm)* and a travel speed of 120 ft/min (36.6 m/min).



MODEL	AP3550	GP3550	GP3000-15
Plate Size WxL	21 x 22 in (53 x 56 cm)		16 x 20 in (41 x 51 cm)
Weight	No Water 229 lbs (104 kg) Full Water 254 lbs (115 kg)	226 lbs (103 kg)	202 lbs (92 kg)
Engine	Honda GX160		
Amplitude	.086 in (1.5 mm)	.087 in (1.5 mm)	.098 in (2.49 mm)
Centrifugal Force**	3550 lbs (15.8 kN)		
Exciter Speed	4400 vpm		
Compaction Depth*	Up to 21 in (53 cm)	Up to 21 in (53 cm)	Up to 16 in (41 cm)
Travel Speed	up to 110 ft/min (34 m/min)	up to 110 ft/min (34 m/min)	up to 120 ft/min (36.6 m/min)
Compaction Area	11550 ft ² /hr (1073 m ² /hr)	11550 ft ² /hr (1073 m ² /hr)	9600 ft ² /hr (892 m ² /hr)

* Clean sand, optimum moisture. MBW recommends that lifts not exceed 12".

** Centrifugal Force is not a measure of compaction performance.

() Metric Measurements. Specifications subject to change without notice.

5000 SERIES



The GP5800 is an upgrade of model GP5500. The GP5800 maintains its predecessor's outstanding performance characteristics while improving the design in terms of ergonomics, ease of

service and product life expectations. Among these are a removable, easily serviced exciter assembly, superior suspension for improved engine isolation, lower hand/arm vibration and standard protective cage surrounding the engine. This high production compactor travels up to 130 ft/min, generates .094 inch amplitude for deep penetration of backfill materials and is unmatched on mid-sized to large commercial and infrastructure applications.

7000 SERIES



The GP7000 is MBW's heavy hitter for jobs with difficult soils and deep lifts of up to 30 in. (76 cm)*. Weighing 653 lbs. (296 kg) with low frequency and high amplitude, this hard working vibratory

plate outperforms walk-behind rollers on most granular applications. The GP7000 is easy to maneuver and features a central lifting bail for easy lift and transport.

MODEL	GP5800	GP7000
Plate Size WxL	23 x 24 in (58 x 61 cm)	26 x 30 in (66 x 76 cm)
Weight	288 lbs (131 kg)	653 lbs (296 kg)
Engine	Honda GX270	Honda GX390
Amplitude	.094 in (2.39 mm)	.166 in (4.22 mm)
Centrifugal Force**	5800 lbs (25.8 kN)	7900 lbs (35.1 kN)
Exciter Speed	4800 vpm	2800 vpm
Compaction Depth*	Up to 20 in (51 cm)	Up to 30 in (76 cm)
Travel Speed	up to 130 ft/min (39.6 m/min)	up to 100 ft/min (30.5 m/min)
Compaction Area	14950 ft ² /hr (1389 m ² /hr)	13000 ft ² /hr (1208 m ² /hr)

* Clean sand, optimum moisture. MBW recommends that lifts not exceed 12".

** Centrifugal Force is not a measure of compaction performance.

() Metric Measurements. Specifications subject to change without notice.



REVERSIBLE

SMALL REVERSIBLE VIBRATORY PLATES



The **GPR 65, 68 and 77** are compact reversible plates ideal for narrow trenches and confined areas.

HEAVY DUTY SHIFTING

The heavy duty mechanical shifting mechanism allows for directional changes at full speed. Endurance testing was terminated at 400,000 shifts without system failure – the best result MBW (and very likely any manufacturer) has ever achieved on a reversible plate shifting design.



SHIFTING HANDLE

The **GPR65** and **GPR68** are also high production plates. Travel speeds to 92 ft/min are achieved with good compaction conditions and the plates move with ease over irregular lift surfaces. Head-to-head competitive demonstration quickly establishes the comparative benefits of the GPR65 and GPR68.

The **GPR77** is a 400 pound reversible plate. The simple yet reliable shifting design lowers acquisition cost, is low maintenance and provides a geo-technical benefit in its ability to shift travel direction at constant speed. The GPR77 produces an amplitude of .066 inches, travels up to 86 ft/min and handles all types of essentially granular soils.

MODEL	GPR65	GPR68
Plate Size WxL	15 x 26 in (38 x 66 cm)	18 x 26 in (46 x 66 cm)
Operating Weight	325 lbs (148 kg)	330 lbs (150 kg)
Engine	Honda GX160	Honda GX160
Amplitude	.072 in (1.83 mm)	.071 in (1.80 mm)
Centrifugal Force**	6000 lbs (27 kN)	6000 lbs (27 kN)
Exciter Speed	4400 vpm	4400 vpm
Compaction Depth*	Up to 22 in (56 cm)	Up to 22 in (56 cm)
Travel Speed	up to 92 ft/min (28 m/min)	up to 88 ft/min (27 m/min)
Compaction Area	6900 ft ² /hr (641 m ² /hr)	7920 ft ² /hr (736 m ² /hr)

* Clean sand, optimum moisture. MBW recommends that lifts not exceed 12".

** Centrifugal Force is not a measure of compaction performance.

() Metric Measurements. Specifications subject to change without notice.

MODEL	GPR77
Plate Size WxL	22 x 26 in (56 x 66 cm)
Engine Options & Operating Weight	77H Honda GX270 397 lbs (180 kg) 77D Hatz Diesel 1B20 399 lbs (181 kg)
Amplitude	.066 in (1.68 mm)
Centrifugal Force**	7775 lbs (35 kN)
Exciter Speed	4725 vpm
Compaction Depth*	Up to 22 in (56 cm)
Travel Speed	up to 86 ft/min (26 m/min)
Compaction Area	9460 ft ² /hr (879 m ² /hr)

* Clean sand, optimum moisture. MBW recommends that lifts not exceed 12".

** Centrifugal Force is not a measure of compaction performance.

() Metric Measurements. Specifications subject to change without notice.



HYDRAULIC SHIFTING REVERSIBLE PLATES



MBW's **HYDRAULIC SHIFTING REVERSIBLE PLATES** solve maintenance problems that have long plagued this product type. MBW exciter systems are vented to prevent damage to shifting seals. Worn shifting seals are readily serviced from the outside of the exciter assembly (patented), eliminating the complicated process of opening and contaminating the exciter assembly for service purposes. Maintenance is simplified, service time is reduced dramatically.

All MBW hydraulic reversibles are easy to maneuver, featuring forward and reverse travel, as well as spot compaction. Powered by Honda gas engines, these reversibles have plenty of power to tackle the toughest compaction applications.

MBW advises users to carefully consider which type of compactor best fits the job. If there is sufficient room to maneuver a single direction plate, productivity, cost and maintenance favor the single direction unit. But where maneuverability is key, reversible plates are the answer.

- Increased weight, amplitude and travel speed
- Powered by GX390 Honda
- Easier to shift direction
- Protected by a full wrap around roll cage
- Lifting bails for ease in handling

- Lower hand arm vibration along with simple, convenient, safe controls at operator's position
- Solid steel plates with substantially higher abrasion resistance & strength than cast
- Infinitely variable travel speed in forward and reverse directions plus spot compaction
- Lower maintenance hydraulic shifting mechanism
- Patented design allows for exchange of lower hydraulic shift seal in approximately 30 minutes versus up to 6 hours in competitive designs
- Only reversible plate line Made in the USA



MODEL	GPR15-24	GPR15-26
Plate Size WxL	24 x 33 in (61 x 84 cm)	26 x 33 in (66 x 84 cm)
Operating Weight	893 lbs (405 kg)	915 lbs (415 kg)
Engine	Honda GX390	
Fuel	Gas	
Centrifugal Force**	14792 lbs (65.8 kN)	
Exciter Speed	4150 vpm	
Compaction Depth*	Up to 28 in (71 cm)	
Travel Speed	up to 90 ft/min (26 m/min)	up to 87 ft/min (26 m/min)
Compaction Area	10800 ft ² /hr (1003 m ² /hr)	11310 ft ² /hr (1051 m ² /hr)
Amplitude Range***	.073 - .104 in (1.85 - 2.64 mm)	.071 - .101 in (1.80 - 2.57 mm)

* Clean sand, optimum moisture. MBW recommends that lifts not exceed 12".
 ** Centrifugal Force is not a measure of compaction performance.
 *** Amplitude based on actual vibratory mass.
 () Metric Measurements

REVERSIBLE



MBW Inc.
 250 Hartford Road • P.O. Box 440
 Slinger, Wisconsin • 53086-0440 • USA
 Ph: 800-678-5237 or 262-644-5234 • Fax: 262-644-5169
 E-mail: mbw@mbw.com • Website: www.mbw.com

MBW Europe Ltd.
 Units 2 & 3 Cochrane Street • Bolton BL3 6BN • England UK
 Ph: 44 (0) 1204 387784 • Fax: 44 (0) 1204 387797
 E-mail: mbwuk@mbw.com or mbweurope@mbw.com
 Europe Website: www.mbw-europe.com

AUTHORIZED DISTRIBUTOR



L16470 08/19
 Copyright ©
 MBW Incorporated
 All Rights Reserved